



City of Ryde

STORMWATER DRAINAGE PLANS Submission Details

Plans and calculations of the proposed property drainage system must be submitted to Council prior to the issue of a Construction Certificate. It is preferred to have as much detail as possible submitted with the Development Application to assist in determining this approval.

The **plans**, prepared at a 1:100 scale, shall include all the following items:

- the location of all buildings, driveways, and impervious surfaces;
- the location, trunk diameter and canopy size (drip line) of any significant trees that may have roots that will be affected by the drainage system, whether or not they are on the subject property;
- the location of all downpipes, surface channels, kerbs, pits, pipes, and sub-surface drainage;
- the size and class of all pipes and the size of all pits;
- the invert levels of all pipes and pits;
- the grades of all pipelines;
- finished surface levels of all pits;
- finished levels of any catch drains or swales;
- finished surface levels of paved areas, unpaved areas, buildings and garages;
- contours at ½ metre intervals of the existing ground levels to Australian Height Datum (AHD);
- the path taken by overland flow during storm events where the capacity of the piped drainage system is exceeded or the system is blocked;
- cross section details of any swales or catch drains proposed;
- a clear indication of the location of easements; the location, size and depth of any Council trunk drainage or interallotment drainage pipelines; and the location of any watercourses passing through the property;
- location of existing buildings or hard paving on the property not being removed as a consequence of the development, and the size and location of all drainage pipes and pits associated with the existing site improvements; and
- details of the connection to Council's drainage system -

if disposal to the kerb	Show the location and levels at the point of discharge into the kerb
if connection to a Council or interallotment drainage pit	show location, size, invert level and surface level of the pit along with the location and size of all pipes entering and leaving the pit.
if slope junction to a Council or interallotment pipeline	show the location, size at level of the pipe at the point of connection, invert and surface levels of pits upstream and downstream from the point of connection and a 1:20 detail of the manner or connection.
Discharge to a natural watercourse	show the location and level of the top and base of the creek banks, levels along the creek bed and a 1:20 detail of the outlet structure.

Where detention storage is required, plans shall include:

- details of the storage facility;
- the path taken by overland flow during storm events when the capacity of the system is exceeded or the system blocked.

If below ground storage is proposed details shall include:

- ⇒ the location and size of the facility
- ⇒ detailed information about the facility including the dimensions of the structure, the floor level, the slope on the floor, the level of the roof, the top water level, the surface level of any access man-holes, the invert level of all inlet pipes, the invert level and diameter of the outlet pipe.
- ⇒ full construction details of the tank or facility, certified by a practising structural engineer as being able to withstand all likely service loads. The details shall include wall, floor and roof slab thickness, reinforcement details, footing details and details of all pit openings.

If above ground storage is proposed details shall include:

- ⇒ sufficient details of finished ground levels within the basin to enable an accurate check of the storage volume provided;
 - ⇒ an elevation showing the outlet control pit and including its invert level, surface level and the top water level; and
 - ⇒ details of the basin overflow provisions.
- details of any orifice outflow control including the plate size, material and thickness, the orifice diameter, the exact location of the orifice on the plate, the exact position of the plate over the outlet pipe, the method for fixing the orifice over the outlet pipe,
 - details of any debris screens including their dimensions, the material used to make to screen, their location, the method for fixing the screen in place,
 - the location, size and proposed construction materials and reticulation system of any rainwater tanks,
 - details of the sediment control sump and the weans of allowing the sump to drain dry,
 - the location and type of any pollution control valves if required,
 - the calculated permitted site discharge (PSD), the storage volume required and the storage volume proposed.

The calculations submitted for roof and site drainage are to be based on a 20 year return interval for a 5 minute storm duration (195 mm/hr zone 1 and 186 mm/hr in zone 2) shall include:

- A catchment plan and calculation sheet detailing the area and surface type of the sub-catchment for each collection point, the quantity of flow in the pipe, and the design capacity.
- A hydraulic grade line analysis for all pipes in excess of 225 mm diameter.
- Full details of input variables and calculations used for the design of the on site detention system, including the selection of the permitted site discharge, the sizing of the storage facility and the design of the outlet control. NOTE; completion and submission of the attached calculation sheet will be sufficient to satisfy this requirement.

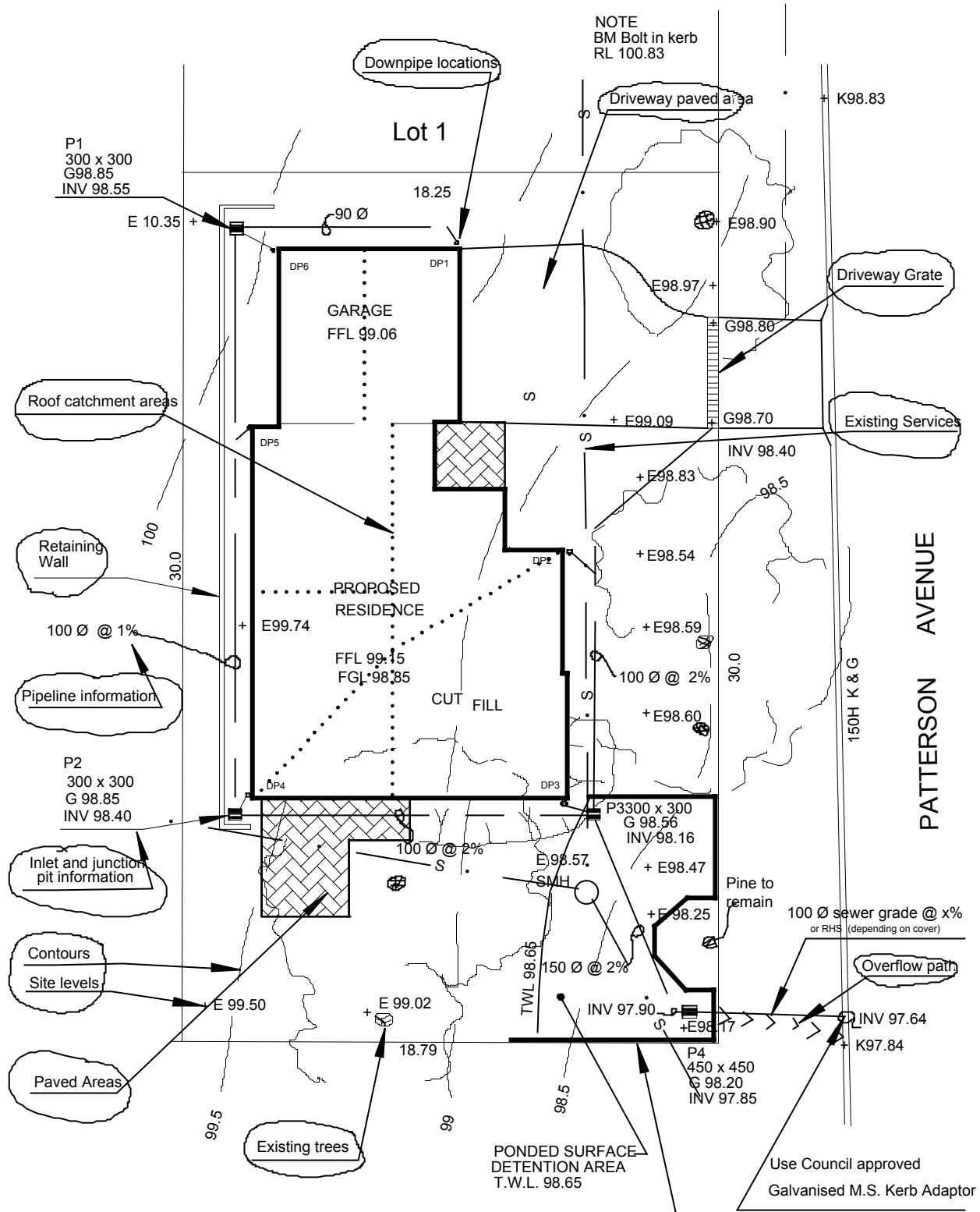

LEGEND

- E - Existing Level
- F - Finished Level
- K - Kerb Level
- KG - Gutter Level
- G - Grate Level
- INV - Invert Level
- TWL - Top Water Level

SYMBOLS

- Proposed Down Pipe
- 150 mm Wide Galvanised Grated Drain
- Tree

EXAMPLE OF DETAILS REQUIRED ON DRAINAGE PLANS FOR SUBMISSION TO RYDE CITY COUNCIL

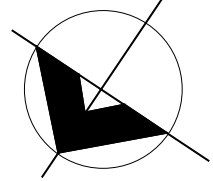

1 : 200

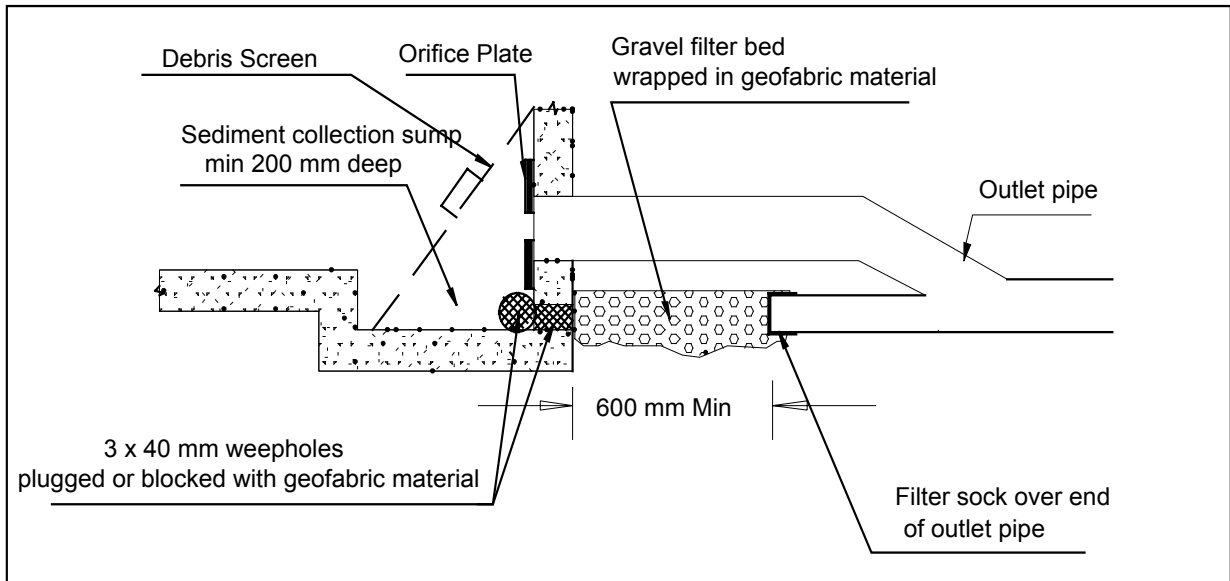

**SEDIMENT COLLECTION SUMP WITH DRAINAGE FILTER
TYPICAL DETAIL OF AN OUTLET CONTROL WITH SIDE
DRAINING SEDIMENT COLLECTION SUMP.**

Note the filter medium between the weepholes and the
connection to the outlet pipeline

Sample catchment analysis sheet for residential development

CATCHMENT AREAS

PIPELINE DESIGN

Description	Area Sq m	Runoff Coeff.	Effective Area Sqm	Time of Conc. min	Rainfall Intensity Mm/hr	Disch'ge L/sec	Accup. Disch'ge L/sec	Pipe Size mm	Grade %	Acc. Capacit y L/sec
DP1 to P1 Roof	18	1	18	5	195	1	1	90	2	7
DP6 to P1 Paving	18 20	1 0.9	18 18	5 5	195 195	1 1	1 1	90	1	4
P1 to P2 Roof DP5	30	1	30	5	195	1.6	5.6	100	1	8
P2 to P3 Roof DP4 Paving	35 15	1 0.9	35 13.5	5 5	195 195	1.9 1	8.5	100	2	12
G1 to P3 Driveway Garden Roof DP2	40 20 20	0.9 0.75 1	36 15 20	5 5 5	195 195 195	2 0.8 1.1	2.8 3.9	100	2	12
P3 to P4 Roof DP3	42	1	4	5	195	2.3	12.4	150	2	28
P4 to Kb Garden	144	0.75	108	7	173	5.2	Contrl. 10.7	100	4	18

+



City of Ryde

ON-SITE DETENTION CALCULATION SHEET

DEVELOPMENT TYPE: _____

ADDRESS: _____

Catchment Zone
(Zone 1) (Zone 2) (Eastwood)

Site Area (m²) _____ (A)

Total Impervious Area (roofs, driveways, hardstand etc) (m²) _____ (B)

Total Area draining to the Storage Facility (m²) (impervious and pervious areas) _____ (C)

Impervious Area bypassing the Storage Facility _____ (D)

$$\frac{(B)+(D)}{(B)} = 1 \text{ _____ (E)}$$

cannot be greater than 1.25.

Permitted Site Discharge (PSD) rate per m²
Catchments in Zones 1 & 2

If (D)=0 then PSD = 0.0265 l/sec/m²

If (D)≠0 then PSD = 0.0265 x (E)^{-1.37} l/sec/m²

Eastwood Catchment

If (D)=0 then PSD = 0.0210 l/sec/m²

If (D)≠0 then PSD = 0.0210 x (E)^{-1.37} l/sec/m² _____ (F)

PERMITTED SITE DISCHARGE (l/s) (C) x (F)

l/s

Storage Volume per m²

(F) = 0.0275 m³/m² for zone 1 or

(F) = 0.0255 m³/m² for zone 2 or

(F) = 0.0300 m³/m² for Eastwood Catchment _____ (G)

SITE STORAGE REQUIREMENT (m³) ((C) + (D)) x (G)

m³

OUTLET CONTROL - using a Sharp Edged Orifice Plate

Height Difference between top water level and Centre of Orifice (m) _____ (H)

ORIFICE DIAMETER (mm)

$$\text{mm} = 21.9 \sqrt{\frac{PSD}{\sqrt{H}}}$$

Should pipe and pit losses be used to control outflow, the calculations are to be attached.

CITY OF RYDE
ON-SITE STORMWATER DETENTION CERTIFICATION SHEET

Address

DA Number Catchment Zone

Required Volumem³ Permissible Site Dischargel/sec

Type of System

Tank	Surface Basin
Description Buffa tank, circular concrete Precast concrete, Brick or block wall Other	Description, Grassed, Landscaped, Paved, Retaining walls:- sleeper, brick, pine log, fill Other
Dimensions Lengthm Width m Depth m	Average lengthm Av Widthm Average Depthm Max Depthm

If over 1 m deep are step irons provided yes/no Has adequate fencing been provided yes/no

Access to tank grate lid other

(can it be easily lifted) yes/no

Adequate grade on base
of tank to drain to outlet yes/no

Actual Volume Attainedm³

Overflow type: Pipe Weir Surface grate
Where is it directed.....

Outlet Stainless Steel orificemm dia
Control Galvanised plate orifice.....mm dia
Othermm dia

Depth from centre of orifice to overflow.....mm

Outflow Attainedl/sec

Outlet Pipe: Where is it directed, kerb, pipe
Other.....

Is connection in accordance with Council
Requirements yes/no

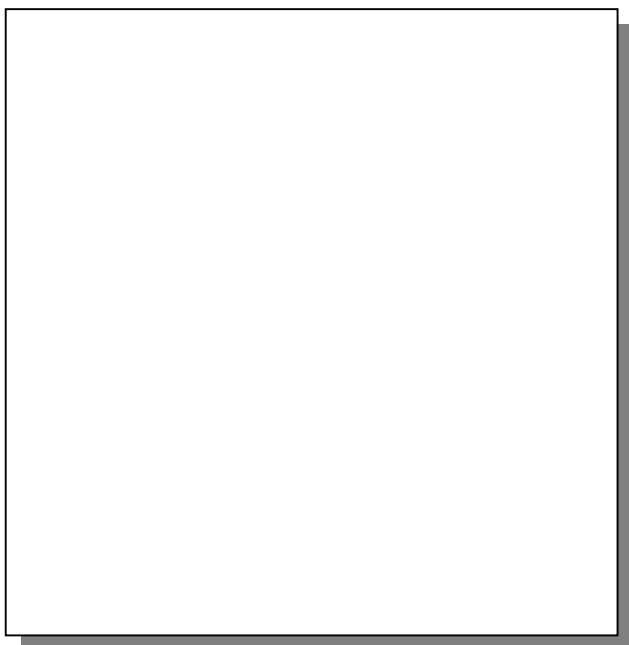

LOCATION SKETCH

Debris Screen Maximesh Is a handle provided yes/no
Other..... Is it readily removable without tools yes/no
Is screen fitted exclusively over outlet yes/no

Silt Trap Dimensions Widemm; Longmm Deepmm Weepholes yes/no
Has subsoil drainage been provided to outlet line yes/no

Is there any uncontrolled flow from the impervious areas on the site . yes/no if yes m²
Can access be easily gained to the system for inspection purposes yes/no

COMMENTS

**I HEREBY CERTIFY THE ABOVE ON-SITE DETENTION STORAGE FACILITY HAS BEEN
CONSTRUCTED IN ACCORDANCE WITH THE APPROVED PLANS**

NAME :.....SIGNATURE. :.....DATE